

Vivitar

www.butkus.us

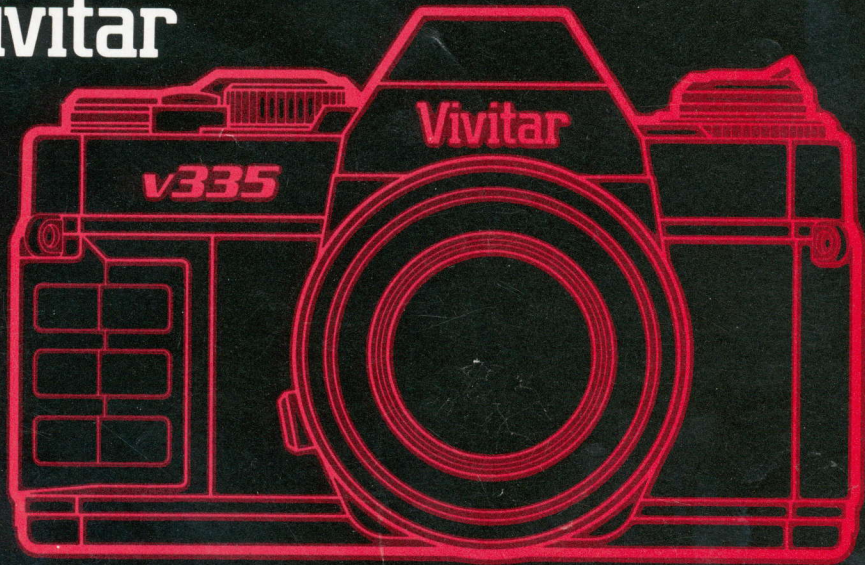

V335

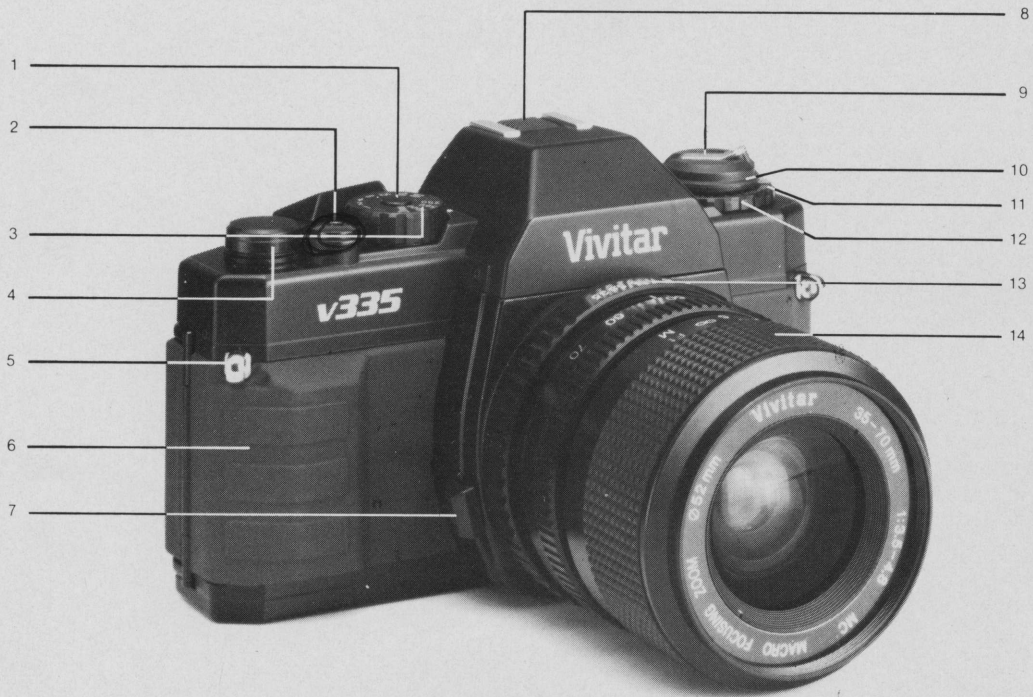

Description of Parts

1. Shutter Speed Dial
2. Shutter Release Button
3. Film Advance Lever
4. Frame Counter
5. Strap Lug
6. Hand Grip
7. Lens Release Button
8. Hot Shoe
9. Film Rewind Crank
10. Film Rewind Knob/Film Compartment
Opening Knob
11. Film Speed Dial
12. Film Speed Index
13. Aperture Ring
14. Focusing Ring
15. Viewfinder Eyepiece
16. Rewind Shaft
17. Film Chamber
18. Battery Compartment Cover
19. Tripod Socket
20. Film Guide Bars
21. Sprocket
22. Back Cover
23. Film Pressure Plate
24. Film Rewind Button
25. Film Take-Up Spool



This manual is for reference and historical purposes, all rights reserved.

This page is copyright© by M. Butkus, NJ.

This page may not be sold or distributed without the expressed permission of the producer

I have no connection with any camera company

On-line camera manual library

This is the full text and images from the manual. This may take 3 full minutes for the PDF file to download.

If you find this manual useful, how about a donation of \$3 to: M. Butkus, 29 Lake Ave., High Bridge, NJ 08829-1701 and send your e-mail address so I can thank you. Most other places would charge you \$7.50 for a electronic copy or \$18.00 for a hard to read Xerox copy.

This will allow me to continue to buy new manuals and pay their shipping costs.

It'll make you feel better, won't it?

**If you use Pay Pal or wish to use your credit card,
click on the secure site on my main page.**

Donate: www.PayPal.me/butkus

venmo: @mike-butkus-camera Ph. 2083

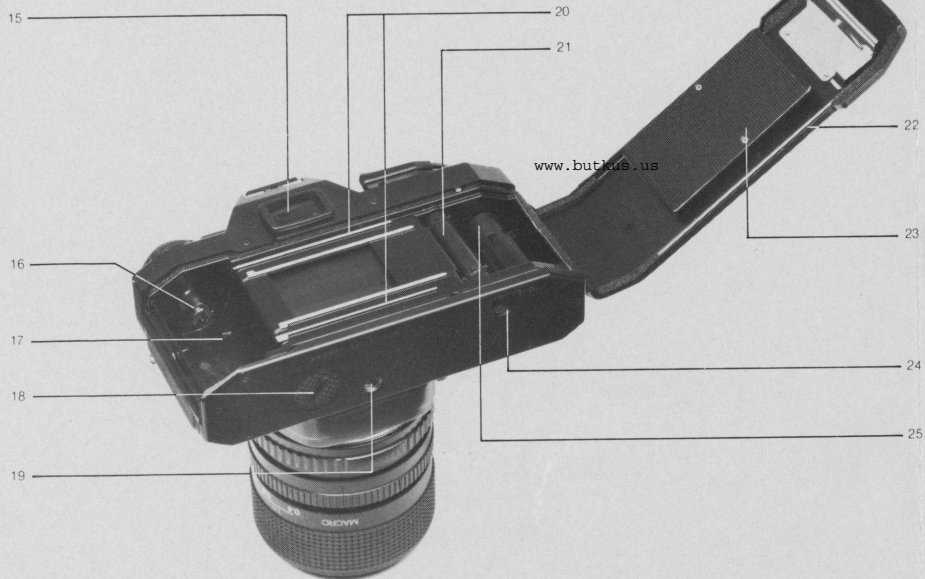

Getting Started

You're probably anxious to take a few pictures. In fact, that's what we strongly recommend doing as soon as possible. First, we'd like you to do a set-up of the camera. This will provide a system check of basic camera functions as well as give you a feel for the camera. We urge you, however, to read this instruction manual completely so that you can get the most enjoyment from your camera.

Photo Tips

At various points in the book, we will give you some tips that will help you take better pictures and care of your camera.

System Set-Up

Please fold out the photographs of your camera from the front and back covers so that you can refer to the numbered call-outs of parts as we go along.

Before You Do Anything Else . . .

1. Pull up on the Rewind Crank (9). The Back Cover (22) will pop open. Remove the white, protective paper and discard it. Firing the shutter with this paper in place could cause damage.
2. Gently close the door until you hear a soft click. Push down on the film rewind knob to reset it.

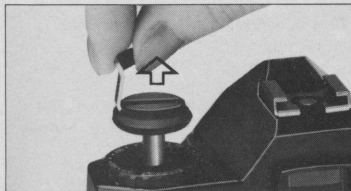

Mounting/Removing the Lens

Your camera utilizes a bayonet "K" mount (also referred to as "PK") and will accept other lenses with a compatible "K" mount designation.

To mount the lens:

1. Match the red dot on the lens with the red dot on the camera mount.
2. Gently insert the lens into the camera mount and turn it clockwise until it clicks into position.
3. To remove the lens, grasp the lens with your left hand and depress the Lens Release Button (7) with your index finger while rotating the lens to the left (counter-clockwise). Gently remove the lens from the camera body.

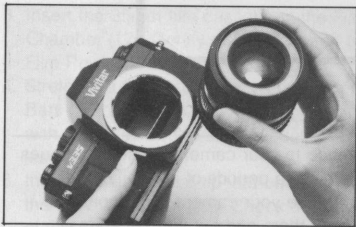

Loading the Batteries

1. With a small coin, rotate the Battery Compartment Cover (18) counter-clockwise and remove it. DO NOT use a screwdriver, because too much force may damage the Cover.
2. Holding the Battery Compartment Cover in your hand, drop in and stack two LR44 or SR44 batteries so that the plus (+) signs are facing up.
3. Replace the Cover. The positive (+) side of the batteries should face the (+) contact at the bottom of the battery compartment. Turn the Cover clockwise with a coin until it stops flush with the bottom plate of the camera. DO NOT OVERTIGHTEN.

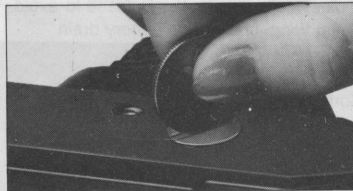

Battery Check

1. With your thumb, pull the Film Advance Lever (3) out about 1/2 inch from the camera body. This is known as the "stand-off" or "ready" position which activates the system electronics.
2. Put the camera up to your eye and gently depress the Shutter Release Button (2) until you see one of the three colored LED symbols (+ O —) light up. When this occurs, you know that your batteries are OK and the system circuits are complete.

If you don't see any lights in the viewfinder, remove the batteries and make sure their positive (+) orientation is correct.

3. Push the Advance Lever back toward the camera body until it stops. This turns off the electronics, locks the Shutter Release to avoid accidental firing, and avoids battery drain.

Photo Tip:

Some photographers replace the batteries in their camera on their birthdays or before annual vacations. Others take them to a camera store and check them. If in doubt, replace them after one year or following extraordinarily heavy use.

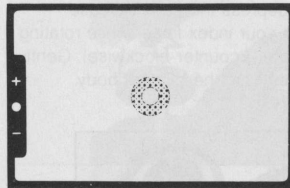
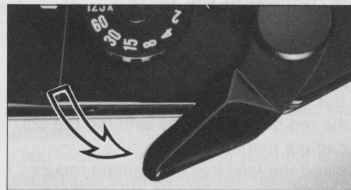

Battery Corrosion

Avoid damage to your camera. Most all batteries will leak after long periods of inactivity. If you don't plan to use your camera for a month or more, remove them and put them in a small plastic bag for safety.

Loading the Film

1. Pull up on the Film Rewind Crank (9) and open the Back Cover (22) all the way to the right.

NOTE: When the Back Cover opens, it automatically resets the Frame Counter (4) to 'S' (zero).

2. Make sure the Film Rewind Crank is in the fully up position.

Photo Tip:

Never load or unload film in direct sunlight. Find some shade or use your body to shade the camera when loading and unloading.

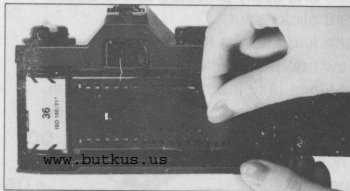
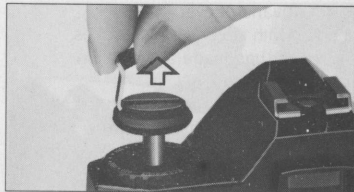

3. Insert the 35mm film cassette in the Film Chamber (17). Gently push down and turn the Film Rewind Crank until it fully seats.
4. Stretch the film leader across the Film Guide Bars (20) as shown. Align the Sprocket (21) with the holes on the bottom edge of the film leader.
5. Insert the film leader tip into one of the slots of the Take-Up Spool (25). Check that the teeth of the Sprocket (21) are engaged in the film's sprocket holes.

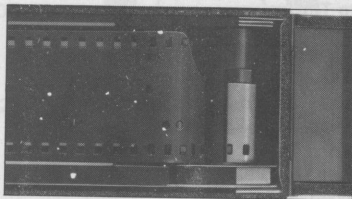

- Using the Film Advance Lever (3), gently advance the film with several short strokes until the film leader has made one rotation around the Take-Up Spool.
- Slowly and gently turn the Film Rewind Crank (9) clockwise in the direction of the arrow until you feel resistance. You have now created the proper tension and film flatness at the film plane.
- Gently close and apply pressure to the Back Cover until it clicks shut.
- Advance the film and fire the shutter by pushing down on the Shutter Release Button (2) several times until the black index mark in the Frame Counter Window (4) is opposite the silver dot between the "0" and "2". The shutter is now cocked and ready for picture number one.

Photo Tip:

When you advance the film, check that the Film Rewind Knob (10) turns at the same time. If it does, the film is advancing properly. *If it doesn't turn*, the film has disengaged from the Take-Up Spool and you should open the back cover and re-thread the film leader as explained above.

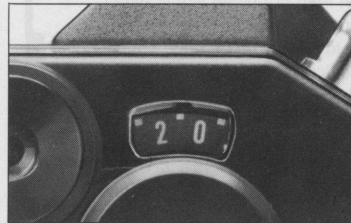
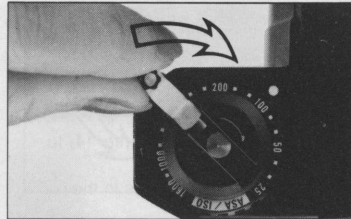

Setting the Film Speed

1. Note the film speed indicated on the film package or instruction sheet.
2. Turn the Film Speed Dial (11) until the ASA/ISO speed of the film is opposite the white Film Speed Index mark (12).

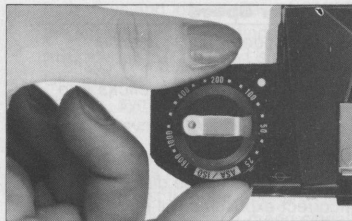

Setting the Lens Aperture

1. With your right thumb, pull the Film Advance Lever (1) away from the camera body about 1/2 inch to activate the camera's distance



2. Hold the camera up to your eye, press down part way on the Shutter Release Button (2) and turn the Aperture Ring (13) on the lens

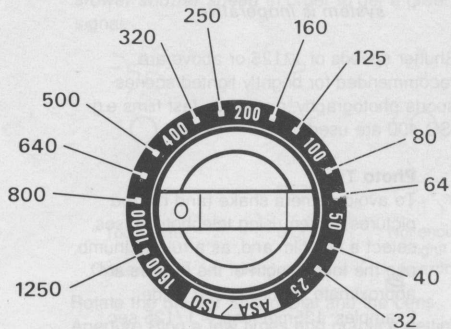

Setting the Shutter Speed

1. Turn the Shutter Speed Dial (1) in either direction until the desired speed is opposite the white index line *and audibly clicks into position*.

NOTE: There are no intermediate speeds in between those on the dial and incorrect exposures will result if interpolated speeds are attempted. In the "B" (bulb) position, *the exposure system is inoperative*.

2. Shutter speeds of 1/125 or above are recommended for brightly lighted scenes, sports photography, and when fast films e.g. ISO 400 are used.

Photo Tip:

To avoid camera shake (and blurred pictures), when using telephoto lenses, select a fast film and, as a rule of thumb, use the focal length of the lens as an approximate shutter speed guide.

Examples: 135mm lens = 1/125 sec.;

500mm lens = 1/500 sec.

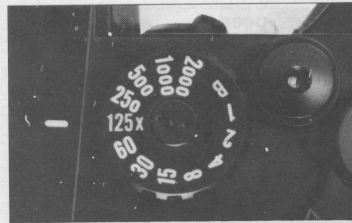

3. SHUTTER SPEED RECOMMENDATIONS WITH ISO 100 FILM

SUBJECT	SHUTTER SPEED
Stationary subjects in low light	1 to 1/15th sec
Indoors in normal conditions	1/20 to 1/60
Outdoors on a clear day	1/125 to 1/250
Fast moving objects	1/250 to 1/2000
Mountains and/or snow scene	1/500 to 1/2000

Setting the Lens Aperture

1. With your right thumb, pull the Film Advance Lever (3) away from the camera body about 1/2 inch to activate the camera's electronics.

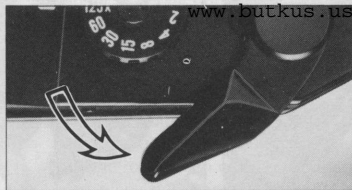

2. Hold the camera up to your eye, press down part way on the Shutter Release Button (2) and turn the Aperture Ring (13) on the lens

both ways and look at the glowing LEDs on the left side of the viewfinder.

RED means STOP! Don't shoot!

GREEN means GO! Shoot the picture.

The "+" symbol means too much light.

The "-" symbol means not enough light.

The circle in the center is like a traffic signal. It turns from red to green when you can "go". Just turn the Aperture Ring in either direction until you get a green signal. If you're in low light, you may have to change to a **slower shutter speed** in order to get a green signal.

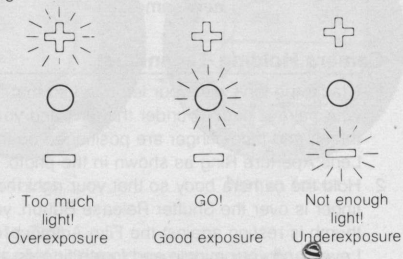

Rotate the Shutter Speed Dial and the Lens Aperture Ring a few times and practice getting the green light.

Photo Tip:

Since the Shutter Speed Dial and Lens Aperture Ring are integrated in the exposure setting, you can use this versatile feature to achieve some interesting results. e.g. use a slower shutter speed to blur the background while you track a moving car or athlete.

This completes the system check of the camera. We urge you to read on for more tips and important facts about your new camera.

Camera Holding Technique

1. Cradle the lens with your left hand so that your palm is directly under the lens and your thumb and index finger are positioned on the Lens Aperture Ring as shown in the photo.
2. Hold the camera body so that your right index finger is over the Shutter Release Button, your thumb is resting against the Film Advance Lever, and your middle and fourth fingers are holding the Hand Grip (6).
3. Bring the camera up to your eye and press your left elbow against your body for camera support. Keep your right arm relaxed.

Photo Tip:

Take a tip from competitive athletes. Don't be tight. To relax, take a deep breath and let it out slowly. Concentrate. Don't push down sharply on the Shutter Release Button. Apply pressure *evenly and smoothly*. Lean against a wall, a fence, or a friend to keep body movement and vibration to a minimum.

Shooting with a telephoto or telezoom lens? USE A TRIPOD.

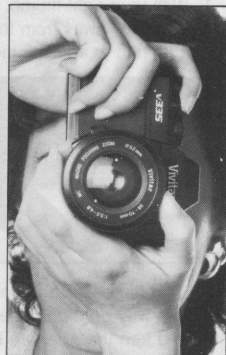
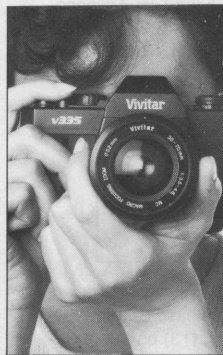

Focusing

Put the camera up to your eye and turn the Focusing Ring (14) on the lens. As you turn the ring you will see three different things happening in the viewfinder:

1. The entire screen will go from a blur to sharp focus. This allows you to focus quickly in situations where you don't have time for "fine tuning" of the focus.
2. The outside ring of the "donut" in the center of the viewfinder will shimmer or appear partially broken and become sharp when you achieve focus. This is one of your "fine tuning" focusing aids, which is especially useful with long telephoto lenses and the viewfinder is not as bright.
3. Inside the "donut" is a split image rangefinder which separates the subject horizontally and aligns it when in focus.

NOTE: Telephoto or telezoom lenses with an aperture of $f/5.6$ or slower may cause the top portion of the split image to "black out" and become unusable. This is normal with slow lenses and there is nothing wrong with the camera.

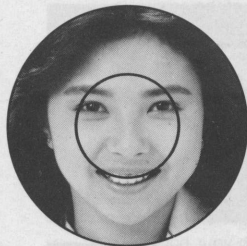
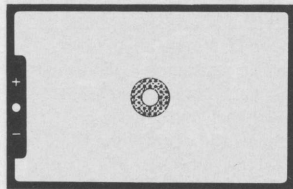

In focus

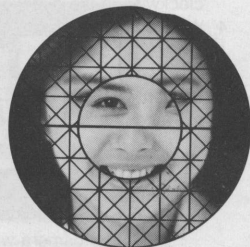

Not in focus

Photo Tip:

Your photo dealer carries a variety of rubber eye cups, diopters, right angle finders and other focusing accessories which are extremely helpful in photography requiring fine focusing, e.g. macro.

Rewinding the Film

1. When you reach the last frame of your film, you will feel a definite resistance in the Film Advance Lever. A glance at the Frame Counter window will verify this.
2. Turn the camera over and depress the Film Rewind Button (24) until it clicks.
3. Fold out the Film Rewind Crank (9) and turn it clockwise in the direction of the arrow.
4. While you're winding, you will feel a certain tension on the crank. When the film leaves the Take-Up Spool and Sprocket, this tension will suddenly stop. Wind for a few more turns to put all of the film into the cassette.

Photo Tip:

Remember. Never load or unload a camera in direct sunlight. Find shade or shade the camera with your body.

5. Gently lift the Film Rewind Crank to pop open the Back Cover. Continue lifting the Crank until it stops to disengage the Rewind Shaft (16). Remove the film cassette and put it immediately in its protective canister.

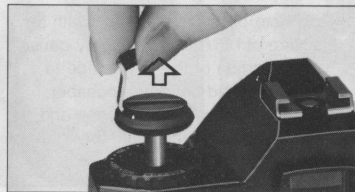
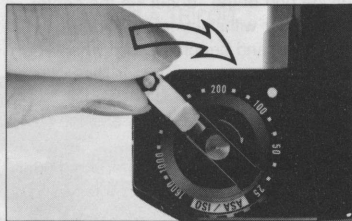
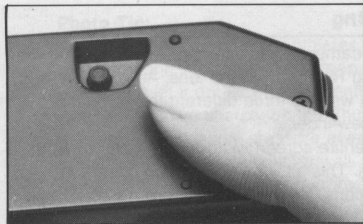

The "B" (Bulb) Setting

When you select 'B' on the Shutter Speed Dial, the shutter will remain open as long as you depress the Shutter Release Button. This is a professional feature which will allow you to shoot "open flash" photos of interiors where multiple exposures are necessary or take time exposures of longer than one second, e.g. a night scene.

Photo Tip:

Use a tripod and cable release!

Electronic Flash Photography

The Hot Shoe (8) on the top of your camera will accept a Vivitar or comparable electronic flash unit. It is electronically coupled to the shutter mechanism and will automatically fire the flash when the shutter is fired.

1. Insert your flash unit into the Hot Shoe. If the flash has a locking knob, turn it to secure the flash to the shoe.
2. Set the Shutter Speed Dial (1) to 1/125 second *or slower*.

NOTE: Electronic flash photography at shutter speeds *faster* than 1/125 are not possible with this camera.

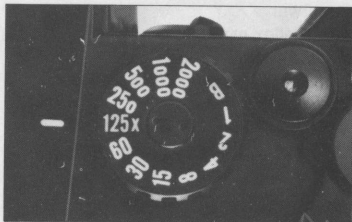
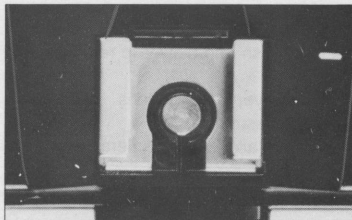
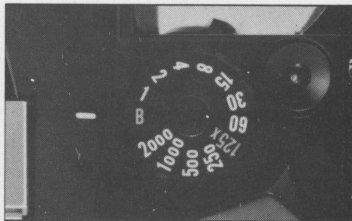

3. Set the appropriate f/stop on the Lens Aperture Ring (13). (Please refer to your flash's instructions to determine aperture values according to the Guide Number of the flash.)

Do's and Don'ts

YOU SHOULD...

1. Care for your camera as you would a fine instrument.
2. Keep it in a case when not in use.
3. Use a camel hair brush and blower to remove dust.
4. Clean the lens and eyepiece with lens cleaning liquid and tissue.
5. Talk to your photo retailer about camera care and use.

NEVER, NEVER...

1. Touch the shutter curtain.
2. Get the camera wet.
3. Try to clean the reflex mirror.
4. Clean the camera with solvents.
5. Leave the camera in your car's trunk, glove compartment, or rear window.
6. Store the camera for a long period without removing the batteries. Or store it unprotected in a hot, humid or dusty environment.
7. Blow compressed air in the mirror box compartment.

Specifications

Camera Type: 35mm SLR with focal plane shutter. TTL metering with 3 LED display.

Film Format: 24mm x 36mm.

Mount Type: Quick release "K" type bayonet mount.

Shutter: Vertical travel, metal focal plane shutter.

Shutter Speeds: B to 1/2000 set manually by adjusting shutter speed dial.

Flash Synchronization: Hot-shoe, X-contact, synchronized at 1/125th second or slower shutter speed.

Viewfinder: Fixed, eye-level pentaprism type. 0.86x image magnification at infinity with 50mm lens. 93 percent horizontal and vertical view of actual picture area.

Focusing Screen: Horizontal split image.

Displays in Viewfinder:

Red + LED	overexposure warning
Green O LED	correct exposure indication
Red — LED	underexposure warning

Exposure Measurement: Open aperture TTL measurement system, center weighted area measurement.

Measurement range: ISO 100/21°: EV3 (f/2, 1/2s) — EV19 (f/16, 1/2000s).

Film Speed Range: ISO 25 to 1600.

Film Advance: Single frame advance, thumb lever action with 135° throw and 30° stand-off. Safety mechanism prevents double-frame advance or double exposure. Shutter release button is interlocked by moving the advance lever to stored position.

Film Rewind: Manual.

Frame Counter: Progressive type, automatically reset when camera back is opened.

Power Source: Two 1.5v alkaline (LR44) or silver (SR44) batteries.

Dimensions: 133 x 85 x 50 mm (5.24 x 3.35 x 1.97 in.).

Weight: 410 g. (14.5 oz.), camera body only.

Specifications are subject to change without notice.